

Simultaneous 160-Gb/s Demultiplexing and Clock Recovery by Utilizing Microwave Harmonic Frequencies in a Traveling-Wave Electroabsorption Modulator

Hsu-Feng Chou, Zhaoyang Hu, John E. Bowers, *Fellow, IEEE*, Daniel J. Blumenthal, *Fellow, IEEE*, Kohsuke Nishimura, Ryo Inohara, and Masashi Usami

Abstract—A traveling-wave electroabsorption modulator (TW-EAM) is used to realize three simultaneous functions: demultiplexing, detection, and pulse generation. These coexisting functions are achieved by utilizing microwave harmonic frequencies in the TW-EAM. When combined with a phase-locked-loop, these functions enable simultaneous optical demultiplexing, electrical clock recovery, and optical clock generation at line-rates of 40 and 160-Gb/s.

Index Terms—Clock recovery, demultiplexing, electroabsorption, optical time-division multiplexing (OTDM), traveling-wave device.

I. INTRODUCTION

OPTICAL demultiplexing and clock recovery are two essential functions for optical time-division-multiplexing (OTDM) systems. The former extracts lower speed tributaries from the high-speed line signal, which is usually beyond the speed of current electronics, whereas the later provides a synchronized clock to control the timing of the demultiplexer and the decision circuit. To reduce the cost and complexity, simultaneous operation of both functions using a small number of devices is of particular interest. Several configurations have been reported in the literature to enable simultaneous demultiplexing and clock recovery [1]–[5], mostly based on electroabsorption modulators (EAMs). In [1], the variation in the output power of the demultiplexer can be monitored as an error signal to control a local oscillator. On the other hand, the EAM can be used as an optical mixer to extract timing information by utilizing its saturation properties [2], [3]. Another approach is to place the demultiplexer in an electro-optic feedback loop with a high-Q filter [4], [5].

In this letter, we propose and demonstrate simultaneous demultiplexing and clock recovery using a traveling-wave electroabsorption modulator (TW-EAM) and a phase-locked loop (PLL). This is an advantageous combination because the

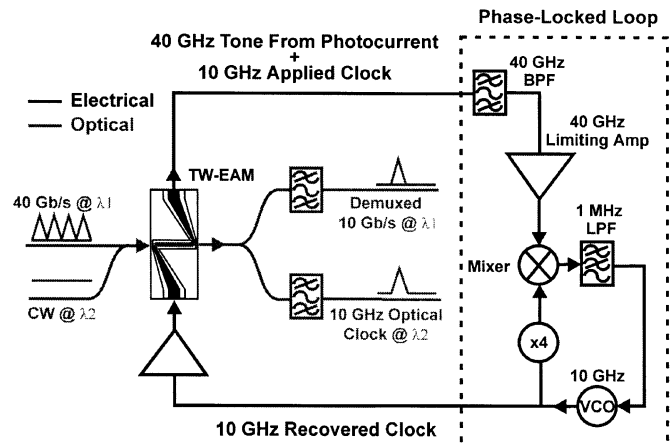

Fig. 1. Setup for 40-Gb/s line rate. BPF: bandpass filter; LPF: lowpass filter; VCO: voltage-controlled oscillator.

TW-EAM has been demonstrated to be a high-performance demultiplexer [6], and the PLL is a well-established technique for clock recovery in the field of electronics and has recently been extended to high-speed optoelectronic applications [7]. In the proposed configuration, simultaneous demultiplexing and electrical clock recovery is realized by utilizing microwave harmonic frequencies in the TW-EAM: A strong tone at the *base rate* is used to drive the TW-EAM as a demultiplexer, and a weak tone at the *line rate* is detected by the TW-EAM as a photodetector for clock recovery with the PLL. At the same time, a synchronized optical clock (optical pulse) can be generated at another wavelength. We first demonstrate simultaneous operation of these functions at 40-Gb/s and then extend them to a line rate of 160-Gb/s by adding another EAM as a prescaler.

II. PRINCIPLE OF OPERATION

Fig. 1 shows the proposed configuration for 40-Gb/s operation. The TW-EAM is designed with traveling-wave electrodes known for overcoming the RC-time limitation of lumped-electrode EAMs. The details of the TW-EAM are described in [8]. The PLL requires an electrical 40-GHz tone (*at the line rate*) extracted from the incoming 40-Gb/s RZ signal to recover a synchronized 10-GHz clock. This 40-GHz tone is provided by

Manuscript received August 6, 2003; revised September 30, 2003. This work was supported in part by the KDDI under Grant 442530-59406 and a State of California UC Discovery Grant 597095-9929.

H.-F. Chou, Z. Hu, J. E. Bowers, and D. J. Blumenthal are with the Department of Electrical and Computer Engineering, University of California, Santa Barbara, Santa Barbara, CA 93106-9560 USA (e-mail: hubert@ece.ucsb.edu).

K. Nishimura, R. Inohara, and M. Usami are with the KDDI R&D Laboratories Inc., 2-1-15 Ohara, Kamifukuoka, Saitama 356-8502, Japan.

Digital Object Identifier 10.1109/LPT.2003.822256

the photocurrent signal from the upper electrical port of the TW-EAM, which now acts as a photodetector [9]. The 3-dB bandwidth of the TW-EAM is 12 GHz with a 50- Ω termination, but the rolloff is not rapid. The recovered 10-GHz clock (*at the base rate*) is fed back into the lower electrical port of the TW-EAM with a proper phase delay to generate a gating window to optically demultiplex 40-Gb/s to 10-Gb/s. This applied 10-GHz clock travels through the TW-EAM and comes out from the upper electrical port together with the 40-GHz tone in the photocurrent. The applied 10-GHz clock is blocked by the 40-GHz bandpass filter at the input of the PLL. Therefore, simultaneous clock recovery and demultiplexing is achieved by utilizing microwave harmonic frequencies without mutual intervention. At the same time, a 10-GHz optical clock is generated by sending a continuous wave (CW) light at another wavelength to the TW-EAM. The generated optical clock is separated from the demultiplexed signal by an optical bandpass filter.

III. EXPERIMENTAL RESULTS

A. 40-Gb/s Operation

The 40-Gb/s RZ signal at 1555 nm is multiplexed from 10 Gb/s with passive delay lines and couplers. The 10-Gb/s RZ signal is generated by modulating a 10-GHz (9.952 597 5 GHz), 5-ps optical pulses from a mode-locked fiber ring laser using an LiNbO₃ modulator with 2³¹ - 1 pseudo-random bit sequence (PRBS). The CW light for optical clock generation is 6 dBm at 1560 nm. Two 2.4-nm optical bandpass filters are used to separate the demultiplexed 10-Gb/s signal at 1555 nm and the generated 10-GHz optical clock at 1560 nm. The 10-GHz electrical clock signal is amplified to 6 V_{p-p} to drive the TW-EAM for demultiplexing and optical clock generation. At 5 dBm of data input power, which is the power level for all the experiments, the locking range is 0.764 MHz. The absolute root-mean-square (RMS) timing jitter of the clock can be obtained by integrating the single side-band (SSB) noise, as shown in Fig. 2(a), from offset frequency 1 kHz to 10 MHz. The RMS timing jitters for the transmitter clock, the recovered electrical clock, and the generated optical clock (with EDFA amplification) are 223, 231, and 232 fs, respectively. The pulsewidth of the generated 10-GHz optical clock is 14 ps. Fig. 2(b) shows the BER curves and the eye diagrams. These eye diagrams are taken with a 40-GHz photodetector and a 50-GHz oscilloscope. BER comparison is done by switching the 10-GHz electrical clock supplied to the TW-EAM and the BER tester from the transmitter clock to the recovered electrical clock. The power penalty is less than 0.2 dB for using the recovered clock, which is very low and close to the measurement resolution. These results show that the proposed concept works well for simultaneous demultiplexing, electrical clock recovery, and optical clock generation at a 40-Gb/s line rate.

B. Extension to 160 Gb/s

The proposed configuration can be extended to a line rate of $N \times 40$ Gb/s by adding another demultiplexer in the front as a prescaler [10]. Fig. 3 shows the simplified setup for 160-Gb/s operation. Another EAM (EAM 2) is adopted as the second demultiplexer. It has a standing-wave enhanced design [11],

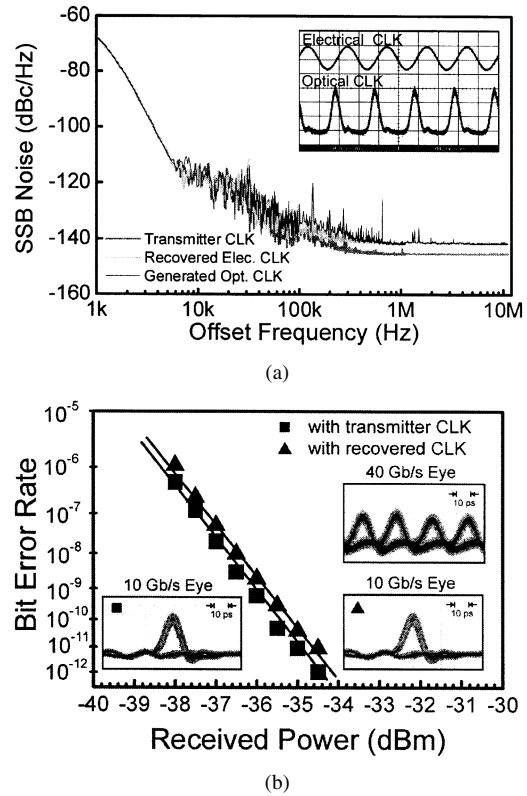

Fig. 2. Results at 40-Gb/s line rate. (a) SSB noise of the transmitter clock, the recovered electrical clock, and the generated optical clock. Insert: traces of the recovered electrical clock and the generated optical clock (50 ps/div). (b) BER curves and eye diagrams measured with the transmitter clock and the recovered electrical clock.

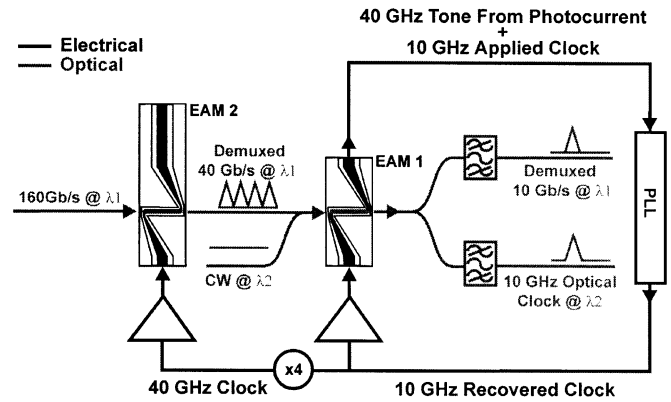

Fig. 3. Setup for 160-Gb/s line rate.

where an open termination is applied and the length of the traveling-wave electrode is extended properly to optimize the 40-GHz E-O response. EAM 2 is driven by a 6 V_{p-p} , 40-GHz signal multiplied from the 10-GHz recovered clock to generate a gating window of 5 ps for the TE polarization, which has lower loss compared with the TM polarization. The polarization dependence of EAM 2 is about 10 dB, which can be reduced by properly compensating the strain in the quantum wells [12]. An EDFA and a 2.4-nm optical filter are inserted between EAM 1 and EAM 2 to compensate for the loss. The 160-Gb/s RZ data signal (5 dBm) is multiplexed passively from 10 Gb/s. The pulses from the mode-locked ring laser are compressed nonlinearly with 5 km of DSF to 2 ps. However, the tails of

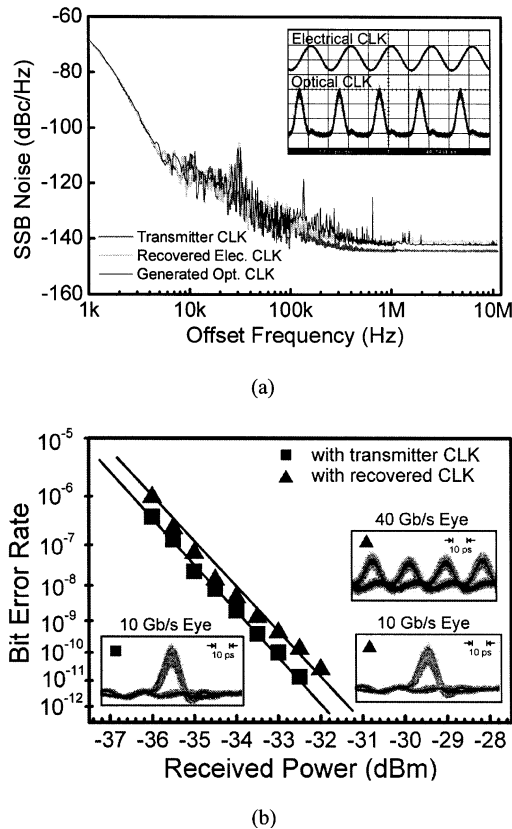

Fig. 4. Results at 160-Gb/s line rate. (a) SSB noise of the transmitter clock, the recovered electrical clock, and the generated optical clock. Insert: traces of the recovered electrical clock and the generated optical clock (50 ps/div). (b) BER curves and eye diagrams measured with the transmitter clock and the recovered electrical clock. The 40-Gb/s eye is demultiplexed from 160 Gb/s by EAM 2.

the compressed pulse are relatively long so that intersymbol interference occurs. To minimize the impact of interference, the 160-Gb/s signal is multiplexed with alternating polarization since the loss of the EAM is higher for the TM polarization, which reduces the interference from adjacent channels [13]. Operation with single polarization multiplexing is possible if the quality of the pulse source is improved. Fig. 4(a) shows the SSB noise of the clocks. The RMS timing jitters are 216, 224, and 229 fs for the transmitter clock, the recovered electrical clock, and the generated optical clock. The BER curves and the eye diagrams are shown in Fig. 4(b). The power penalty for using the recovered clock is less than 0.5 dB and can be attributed to two causes. One is the slightly increased jitter of the recovered clock whose influence is enhanced by two stages of demultiplexers. The other is a slight difference in power (~ 0.5 dB) between the transmitter clock and the recovered electrical clock that are fed into EAM 2, which is sensitive to the driving power. Though not demonstrated in this work, EAM 2 can also be used to generate synchronized optical clocks at 40 GHz.

IV. CONCLUSION

In conclusion, three simultaneous functions (OTDM demultiplexing, electrical clock recovery, and optical clock generation) are realized by utilizing two microwave harmonic frequencies and two independent optical wavelengths in a TW-EAM. It is demonstrated that the recovered electrical and optical clocks have timing jitters as low as that of the transmitter clock. This concept is demonstrated at 40 Gb/s and extended to 160 Gb/s by adding another EAM, which can potentially be scaled to even higher bit rates with a proper front demultiplexer. Very low power penalties under 0.5 dB are obtained at both line rates.

REFERENCES

- [1] I. D. Phillips, A. Gloag, D. G. Moodie, N. J. Doran, I. Bennion, and A. D. Ellis, "Simultaneous demultiplexing and clock recovery using a single electroabsorption modulator in a novel bi-directional configuration," *Opt. Commun.*, vol. 150, pp. 101–105, 1998.
- [2] K. Shimomura, K. Shimizu, K. Ishida, T. Sugihara, and N. Y. Kobayashi, "A simple optical demultiplexing method using saturable absorption of EA modulator," in *Proc. 26th Eur. Conf. Opt. Commun.*, vol. 3, 2000, pp. 305–307.
- [3] E. S. Awad, P. S. Cho, N. Moulton, and J. Goldhar, "All-optical timing extraction with simultaneous optical demultiplexing from 40 Gb/s using a single electroabsorption modulator," *IEEE Photon. Technol. Lett.*, vol. 15, pp. 126–128, Jan. 2003.
- [4] J. Yu, K. Kojima, N. Chand, A. Ougazzaden, C. W. Lentz, M. Geary, J. M. Freund, and B. Mason, "Simultaneous demultiplexing and clock recovery of 80-Gb/s OTDM signal using a Tandem electro-absorption modulator," in *Proc. 14th Annu. Meet. IEEE Lasers Electro-Optics Soc.*, 2001, pp. 358–359.
- [5] T. Miyazaki and F. Kubota, "Simultaneous demultiplexing and clock recovery for 160-Gb/s OTDM signal using a symmetric Mach-Zehnder switch in electrooptic feedback loop," *IEEE Photon. Technol. Lett.*, vol. 15, pp. 1008–1010, July 2003.
- [6] H.-F. Chou, Y.-J. Chiu, W. Wang, J. E. Bowers, and D. J. Blumenthal, "Compact 160-Gb/s demultiplexing using a single-stage electrically gated electroabsorption modulator," *IEEE Photon. Technol. Lett.*, vol. 15, pp. 1458–1460, Oct. 2003.
- [7] D. T. K. Tong, K.-L. Deng, B. Mikkelsen, G. Raybon, K. F. Dreyer, and J. E. Johnson, "160 Gbit/s clock recovery using electroabsorption modulator-based phase-locked loop," *Electron. Lett.*, vol. 36, no. 23, pp. 1951–1952, 2000.
- [8] Y.-J. Chiu, H.-F. Chou, V. Kaman, P. Abraham, and J. E. Bowers, "High extinction ratio and saturation power traveling-wave electroabsorption modulator," *IEEE Photon. Technol. Lett.*, vol. 14, pp. 792–794, June 2002.
- [9] T. Miyazaki, N. Edagawa, M. Suzuki, and S. Yamamoto, "Novel optical-regenerator using electroabsorption modulators," in *Tech. Dig. Opt. Fiber Commun. Conf.*, 1999, pp. 350–352.
- [10] B. Mikkelsen, G. Raybon, R.-J. Essiambre, A. J. Stentz, T. N. Nielsen, D. W. Peckham, L. Hsu, L. Gruner-Nielsen, K. Dreyer, and J. E. Johnson, "320-Gb/s single-channel pseudolinear transmission over 200 km of nonzero-dispersion fiber," *IEEE Photon. Technol. Lett.*, vol. 12, pp. 1400–1402, Oct. 2000.
- [11] H.-F. Chou, Y.-J. Chiu, and J. E. Bowers, "Standing-wave enhanced electroabsorption modulator for 40-GHz optical pulse generation," *IEEE Photon. Technol. Lett.*, vol. 15, pp. 215–217, Feb. 2003.
- [12] S. Z. Zhang, Y.-J. Chiu, P. Abraham, and J. E. Bowers, "25-GHz polarization-insensitive electroabsorption modulators with traveling-wave electrodes," *IEEE Photon. Technol. Lett.*, vol. 11, pp. 191–193, Feb. 1999.
- [13] E. Lach, M. Schmidt, K. Schuh, B. Junginger, G. Veith, and P. Nouchi, "Advanced 160 Gbit/s OTDM system based on wavelength transparent 4×40 Gbit/s ETDM transmitters and receivers," in *Tech. Dig. OFC*, 2002, pp. 2–4.