

Effect Of Direct PRBS Modulation on Laser Driven Fiber Optic Gyroscope

Sarat Gundavarapu, Tin Komljenovic, Minh A. Tran, Michael Belt, John E. Bowers, Daniel J. Blumenthal

Department of Electrical and Computer Engineering
University of California, Santa Barbara
Santa Barbara, CA 93106, U.S.A
saratchandra@ece.ucsb.edu

Abstract—We demonstrate that direct frequency modulation with a pseudo random bit sequence (PRBS) improves the angle random walk (ARW) and bias instability (BIS) for a laser-driven fiber optic gyroscope over a continuous wave (CW) laser driven gyroscope. The PRBS modulation is shown to improve the ARW to 0.076 deg/hr^{1/2} and BIS to 2.298 deg/hr compared to an ARW of 0.172 deg/hr^{1/2} and BIS of 5.862 deg/hr for the CW case.

Keywords—Gyroscopes; Frequency modulation; Coherence

I. INTRODUCTION

MEMS gyroscopes, laser gyroscopes, and interferometric fiber optic gyroscopes (IFOG) are among the commercially mature and available technologies that are widely used in navigation, tactical, and industrial applications. The first laboratory demonstration of an IFOG used a laser as the source [1]. However, the large coherence length of the laser resulted in several parasitic effects that limited the gyroscope performance [2]. The invention of the Erbium doped fiber ASE (amplified spontaneous emission) source with its broad spectrum and low coherence length provided a source that addressed these parasitic effects including phase to amplitude noise from scattering and improved system performance [2]. Current commercial IFOGs utilize super luminescent diodes (SLED) or Erbium-doped/ fiber (EDF) based sources. EDF based sources generally offer the best performance, but at the same time are more costly and difficult to package.

The use of a laser instead of a broadband source in an optical gyroscope can significantly reduce the size, cost, and power consumption due to higher wall-plug efficiency. We have recently demonstrated an interferometric optical gyroscope using a 3 m ultra low loss Si₃N₄ waveguide coil [3, 4]. Our goal is to realize a chip-scale gyroscope with Si₃N₄ waveguide coil and a hybrid Silicon laser [5]. The challenge in using a continuous wave laser is the large coherence length in comparison to a broadband source. The long coherence length increases the effect of noise sources such as Kerr nonlinearity, Rayleigh backscattering and back reflections on the performance of the gyroscope. Reduction of the coherence length of the laser using frequency modulation (FM) has been reported to cause a significant decrease in the effect of these noise sources [6]. Our previous work [7, 8, 9] demonstrated improvement in both ARW and BIS of gyroscope with an FM laser source using single-tone and two-tone modulation

schemes.

A substantial decrease in gyroscope errors has been reported in [10] using an externally phase modulated laser driven by PRBS. In this paper we show that major improvements in the IFOG sensitivity and drift can be achieved using *direct* PRBS modulation of the laser over single and dual tone modulation without the need for a modulator. Use of direct modulation instead of high-speed external phase modulation can reduce the cost and power consumption of the gyroscope.

II. EXPERIMENTAL SETUP

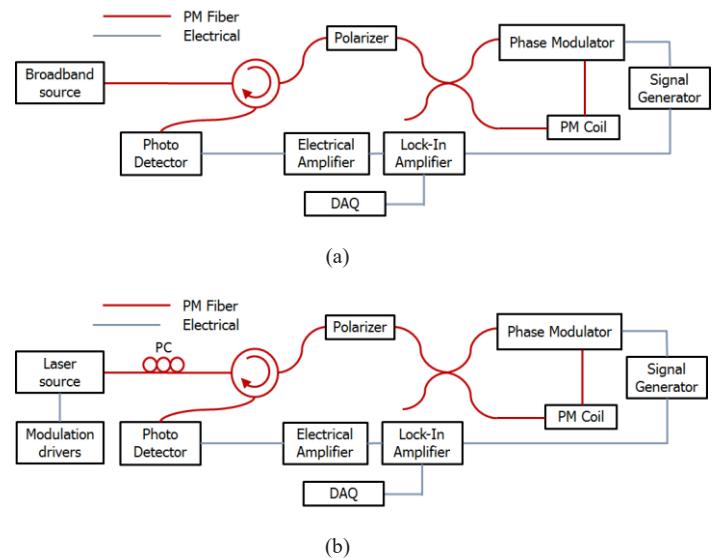

Figure 1: Gyroscope measurement setup using (a) broadband source and (b) modulated laser source

To minimize the effect of thermal transients and polarization drift, a 235 m polarization maintaining (PM), quadrupolar wound fiber coil with a diameter of ~8 cm was used in our gyroscope assembly as shown in Figure 1. The polarization of the laser source was optimized (Figure 1 (b)) to maximize the power at the detector. We first characterized the performance of the gyroscope using a broadband source and compared the performance using a temperature stabilized Alcatel A1905 LMI DFB laser. The nominal spectral width of

the laser used was specified as 2 MHz with relative intensity noise level at -140 dB/Hz.

Coherence length measurements of the laser source were performed with an ultra-high resolution (5 MHz) optical spectrum analyzer using the technique described in [8]. The laser was directly modulated with a PRBS31 sequence ($V_{p-p} = 1$ V) to modulate the laser using an Anritsu MP1763C pattern generator. The coherence length of the CW laser was measured to be 3.8 m and it decreased to < 80 mm when the modulation frequency of the PRBS signal was set to 500 MHz. The modulation frequency range was limited by the bandwidth of the RF connections to the laser mount.

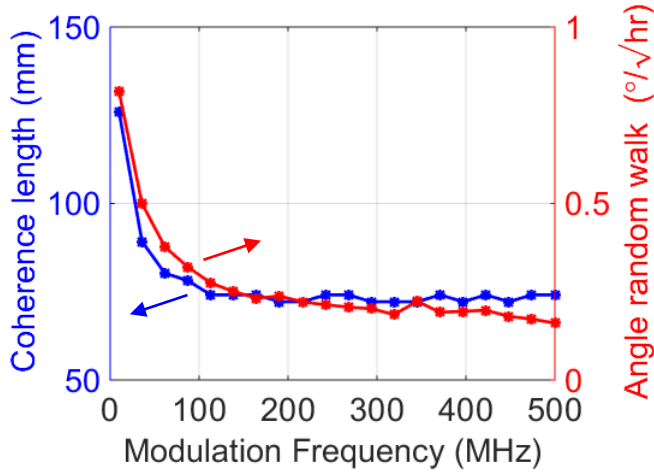

Figure 2: Effect of coherence length of laser on angle random walk of the gyroscope

A precision rotation stage was used to calibrate the sensitivity of the IFOG and Allan deviation measurements were performed with the gyroscope at rest. (Samples were collected for 10 mins at 50 samples/sec). Figure 2 shows that a decrease in the coherence length of the laser source with increasing frequency of PRBS modulation input causes a corresponding decrease in ARW of the gyroscope. A similar decrease of bias instability was also observed with decreasing coherence length.

Long term (1 hour) Allan deviation measurements with a CW laser, PRBS direct modulated laser and ASE source are plotted in Figure 3. Table 1 summarizes the key parameters of these measurements. While PRBS-driven FM laser significantly improves the performance of gyroscope when compared to the CW case, the impact of residual errors related to drift and back scattering still cause the broadband source to outperform the laser driven gyroscope. This can be improved further by employing a closed loop gyroscope configuration.

III. FUTURE DIRECTIONS AND CONCLUSION

As pointed out in [10], the effect of modulation on performance of a FM laser gyroscope depends on the correlation between side bands of the modulated laser. Accordingly, a higher speed RF modulation which makes the side bands uncorrelated will help us achieve better sensitivity and drift. The performance can be improved further with the

use of hollow-core fiber [11] to reduce the impact of parasitic noises such as Shupe effect, and Kerr effect, increase of coil length and area. Optimization of modulation depth, and the use of other modulation signals such as additive white Gaussian noise can help in achieving better ARW.

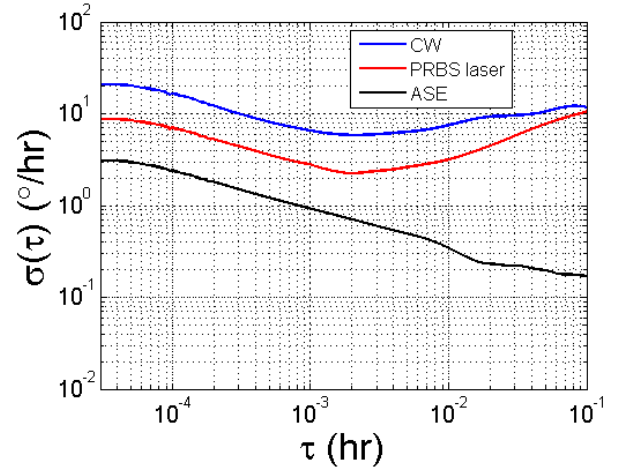

Figure 3: Comparison of performance of gyroscope driven using CW laser, FM laser, and a broadband source

TABLE I.

Optical source	Modulation parameters	ARW (deg/hr ^{1/2})	BIS (deg/hr)
Broadband source	N/A	0.026	0.177
CW laser	N/A	0.172	5.862
PRBS FM laser	300 MHz, 424 mV (p-p)	0.076	2.298

ACKNOWLEDGMENTS

The authors would like to thank Robert Lutwak and Taran Huffman for useful discussions. This work was supported by DARPA MTO under iWOG contract No: HR0011-14-C-0111. The views and conclusions contained in this document are those of the authors and should not be interpreted as representing official policies of DARPA or the U.S. Government. Tin Komljenovic was supported by NEWFELPRO Grant No. 25.

REFERENCES

- [1] Vali, Victor, and R. W. Shorthill. "Fiber ring interferometer." *Appl. Opt* 15.5 (1976): 1099-1100.
- [2] H. C. Lefevre, "The Fiber-Optic Gyroscope", Artech House (2014).
- [3] S. Gundavarapu, T. Huffman, M. Belt, R. Moreira, J. Bowers, and D. Blumenthal, "Integrated Ultra-Low-Loss Silicon Nitride Waveguide Coil for Optical Gyroscopes," in *Optical Fiber Communication Conference, OSA Technical Digest (online)* (Optical Society of America, 2016), paper W4E.5.
- [4] Sarat Gundavarapu, Michael Belt, Taran Huffman, Minh A. Tran, Tin Komljenovic, John E. Bowers, and Daniel J. Blumenthal, "Integrated Sagnac Optical Gyroscope Sensor Using Ultra-Low Loss High Aspect Ratio Silicon Nitride Waveguide Coil", in *Optical Fiber Sensors Conference 2017* (Accepted)
- [5] Srinivasan, S., Moreira, R., Blumenthal, D., & Bowers, J. E. (2014). Design of integrated hybrid silicon waveguide optical gyroscope. *Optics express*, 22(21), 24988-24993.

- [6] Blin, Stéphane, Michel JF Digonnet, and Gordon S. Kino. "Fiber-optic gyroscope operated with a frequency-modulated laser." 19th International Conference on Optical Fibre Sensors. International Society for Optics and Photonics, 2008.
- [7] Shen, Y., M. Tran, S. Srinivasan, J. Hulme, J. Peters, M. Belt, S. Gundavarapu, Y. Li, D. Blumenthal, and J. E. Bowers. "Frequency modulated laser optical gyroscope." In Photonics Conference (IPC), 2015, pp. 431-432. IEEE, 2015.
- [8] Komljenovic, T., Tran, M. A., Belt, M., Gundavarapu, S., Blumenthal, D. J., & Bowers, J. E. (2016). Frequency modulated lasers for interferometric optical gyroscopes. *Optics letters*, 41(8), 1773-1776.
- [9] Tran, M. A., Gundavarapu, S., Belt, M., Komljenovic, T., Blumenthal, D. J., & Bowers, J. E. (2016, June). Frequency modulate laser based interferometric optical gyroscope. In *Lasers and Electro-Optics (CLEO), 2016 Conference on* (pp. 1-2). IEEE.
- [10] Chamoun, Jacob, and Michel JF Digonnet. "Pseudo-random-bit-sequence phase modulation for reduced errors in a fiber optic gyroscope." *Optics Letters* 41.24 (2016): 5664-5667.
- [11] Digonnet, Michel JF, Seth W. Lloyd, and Shanhui Fan. "Coherent backscattering noise in a photonic-bandgap fiber optic gyroscope." 20th International Conference on Optical Fibre Sensors. International Society for Optics and Photonics, 2009.